



Yale seria US06 270 kg

Zastosowanie

Zwory serii US06 przeznaczone są do realizowania kontroli dostępu w pomieszczeniach wymagających podstawowej ochrony np. drzwi wewnętrzne.

Właściwości

Montaż nawierzchniowy
Korpus aluminiowy – wykończenie szczotkowane
Zasilanie dualne 12V lub 24V
Wkręty mocujące i płyta dociskowa w zestawie
Płyta montażowa w zestawie
Czujnik Hall'a w opcji (sygnalizuje że drzwi są zamknięte i zwora ma zasilanie)
Kontaktron w opcji

Parametry techniczne

Siła trzymania: 270 kg
Napięcie zasilania: 12 lub 24Vdc (wyb.)
Pobór prądu: 480mA±10%/12Vdc /
240mA±10%/24Vdc

Dostępne wersje:

Oznaczenie	EAN	Opis
45-US06-V000-00-60-11	5052847053973	Zwora Yale 270kg/12-24V
45-US06-VL00-00-60-11	5052847053980	Zwora Yale 270kg Hall sens/ 12-24V
45-US06-VLM0-00-60-11	5052847053997	Zwora Yale 270kg Hall + kontaktron/12-24V

Elementy montażowe:

45-B006-LN00-00-60-80	5052847054109	Płyta montażowa L Yale 270
45-B006-U100-00-60-80	5052847054116	Płyta montażowa G Yale 270
45-B006-LZ00-00-60-80	5052847054123	Płyta montażowa Z Yale 270
45-B006-GG00-00-60-80	5052847054130	Płyta montażowa GG Yale 270
45-B006-AH00-00-60-80	5052847054147	Płyta montażowa M Yale 270

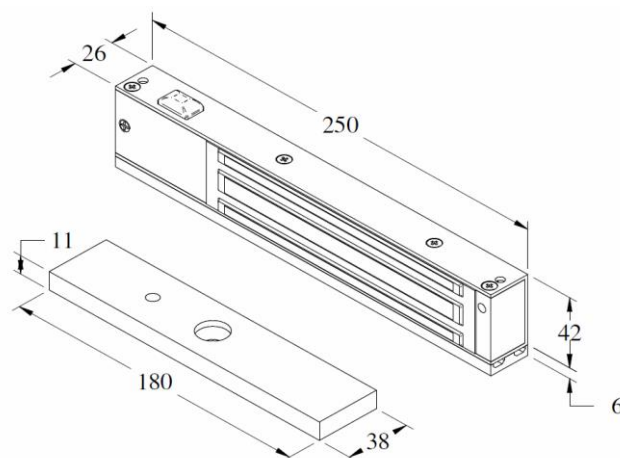

INSTRUKCJA SERII ZEWNĘTRZNEGO OKABLOWANIA

UWAGA!

Przed podłączeniem instalacji do prądu,
sprawdź czy przewody są poprawnie podłączone.



12 VDC

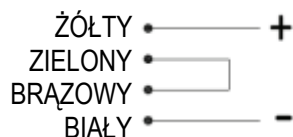

24 VDC

CZUJNIK KONTRAKTONA



DIAGRAM INSTALACJI NAKRĘTKI ZACISKOWEJ

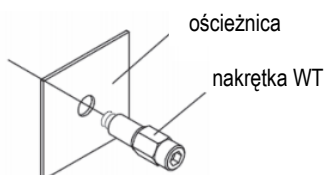

1. Wywiercić otwór o średnicy 9,4 i umieścić nakrętkę zaciskową M6 w nakrętce WT.

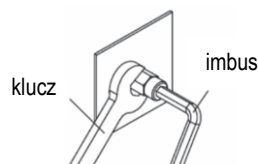

2. Powoli dokręcać nakrętkę zaciskową przy użyciu klucza i imbusa. Usunąć nakrętkę WT po dokręceniu.

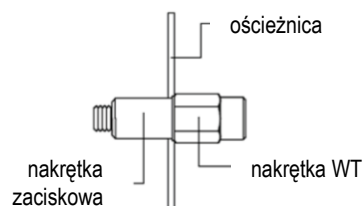

PRZED



PO

INSTRUKCJA SERII ZEWNĘTRZNEGO OKABLOWANIA

UWAGA!

Przed podłączeniem instalacji do prądu,
sprawdź czy przewody są poprawnie podłączone.



12 VDC



24 VDC

CZUJNIK KONTRAKTONA



DIAGRAM INSTALACJI NAKRĘTKI ZACISKOWEJ

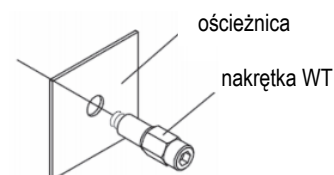

1. Wywiercić otwór o średnicy 9,4 i umieścić nakrętkę zaciskową M6 w nakrętce WT.



2. Powoli dokręcać nakrętkę zaciskową przy użyciu klucza i imbusa. Usunąć nakrętkę WT po dokręceniu.

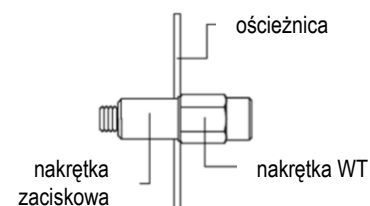

PRZED



PO

Electromagnetic Lock Install Instruction

Usage : Security door, Fire door, any framed sliding door, pushing door (in-swing door need L-bracket and Z-bracket)

and Z-bracket)

Signal output: Magnetic indicate output, can extend to other access control system device.

Choosing correct voltage:

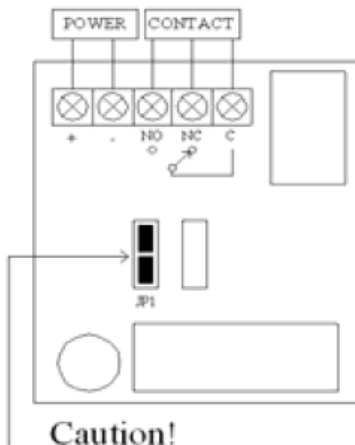

Caution!

Before power on the unit, set input Voltage Selector JP1 according to the supply voltage.



Note: When magnet body and sheer strike plate (armature plate) closed, the juncture is NO. (LED turn to green)

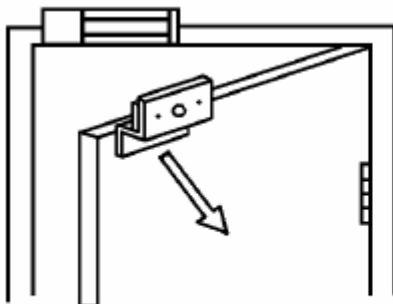

In Swing door

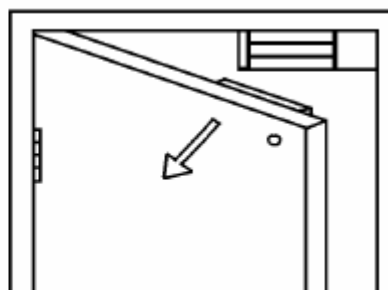

Out-swing door

Figure 1: In-swing door assembly

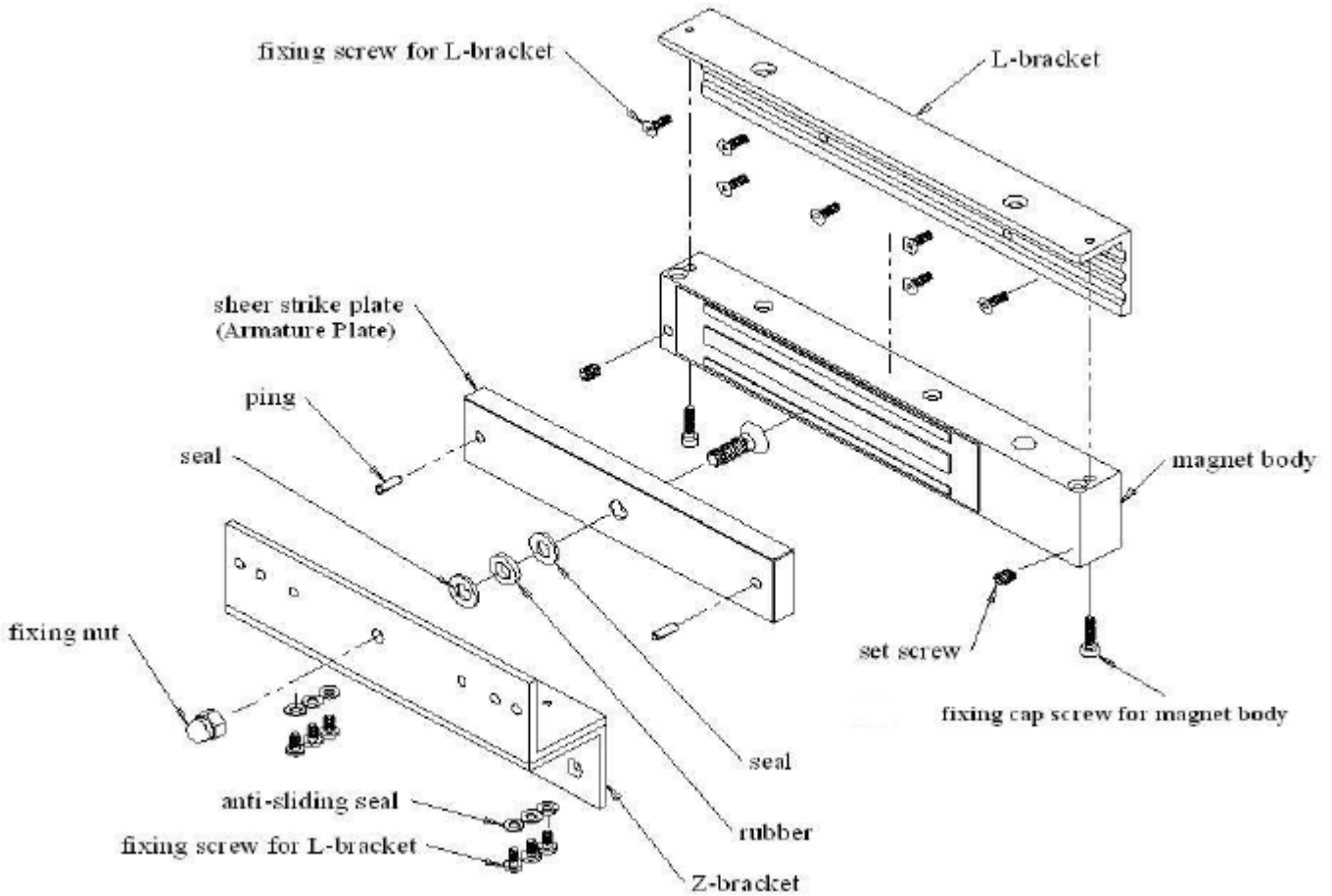

1. According to the door frame location, set the approximate position of the L-bracket in the door frame. Using the cap screw at 2 interior side affix the magnet body to the L-bracket. Then, lock the set-screw tightly to prevent the cap screw from loosening.

2. Accommodate the sheer strike plate (armature plate) to the Z-bracket, lock to the door. Make sure it is at relative position to the magnet body. The Z-bracket fixing-screw can adjust forward or backward to make the distance between magnet body and sheer strike plate properly when door closed. Then, lock the Z-bracket fixing-screw tightly.

Note: To prevent sliding status, Z-bracket fixing-screw must accommodate with anti-sliding seal.

3. There must have 2 seals and 1 rubber seal between sheer strike plate and Z-bracket. Put rubber seal between 2 seals. Lock the M8 flattop screw on the middle of the sheer strike plate to Z-bracket.

Make sure the sheer strike plate can be slightly shaken when locked. This will have better conjunction to the magnet body, and reach the best efficiency.

Figure 1a with ZL Bracket

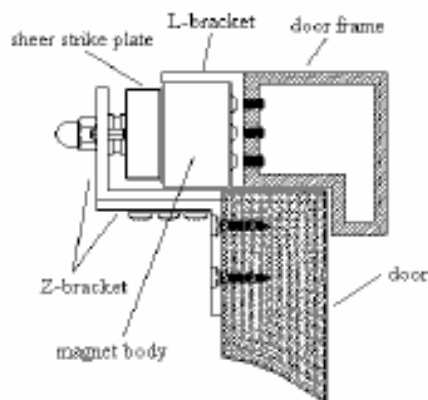
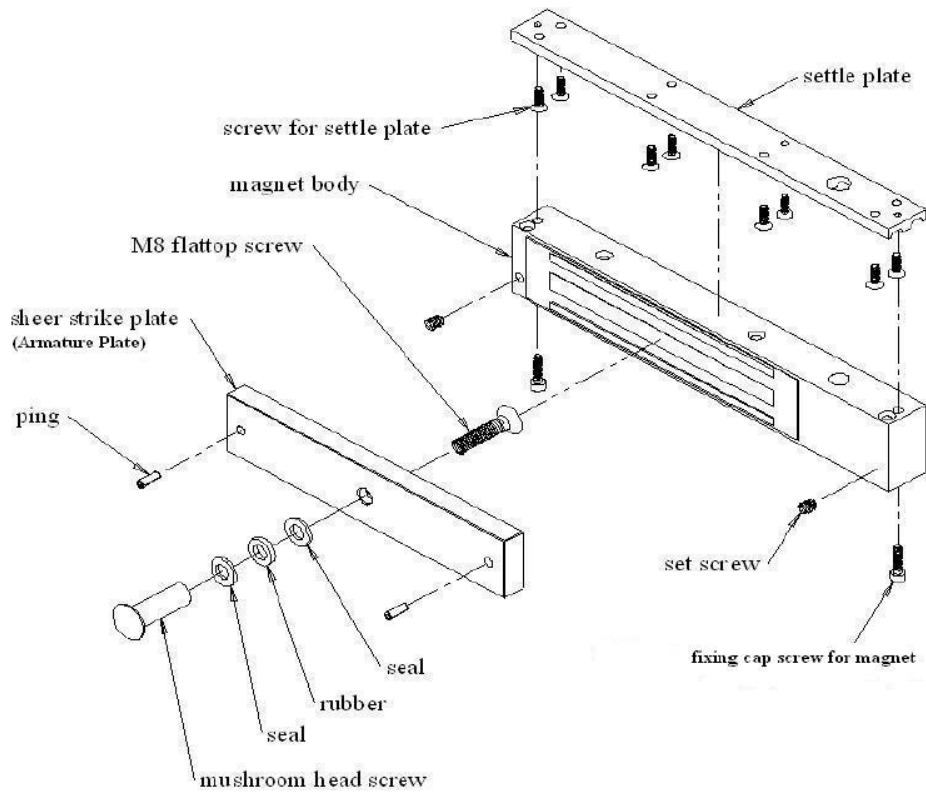

Figure 2: Out-swing door assembly



1. Insert 2 screws into the rectangular holes on the two sides of settle plate, lock the settle plate on the door frame.

Note: Do not tight the screw to adjust to correct position. After verify correct position, tight all screw on the settle plate. Then lock the magnet body onto the settle plate and lock the set screw.

2. When make sure the sheer strike plate position, drive a hole on the door by the size of M8 screw at the center of sheer strike plate position (To fit mushroom head screw and aluminium hollow pipe). Insert 2 pings, drive match holes (5-6mm diameter) on the door.

3. Between sheer strike plate and door, install 2 seals and 1 rubber seal. Rubber seal in the middle of 2 seals. Behind the door, insert aluminium hollow pipe (length depends on the door thickness). Using mushroom head screw to lock sheer strike plate on the door.

Note: Make sure the plate can be slightly shaken when locked. This will have better conjunction to the magnet body, and reach the best efficiency.

Figure 2a With Standard Bracket

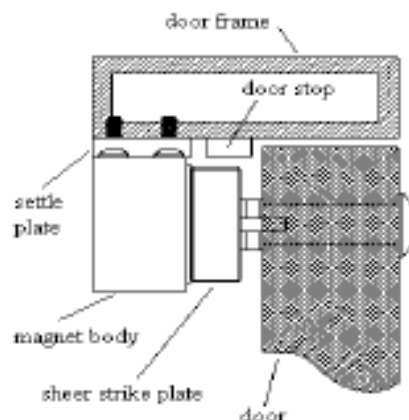
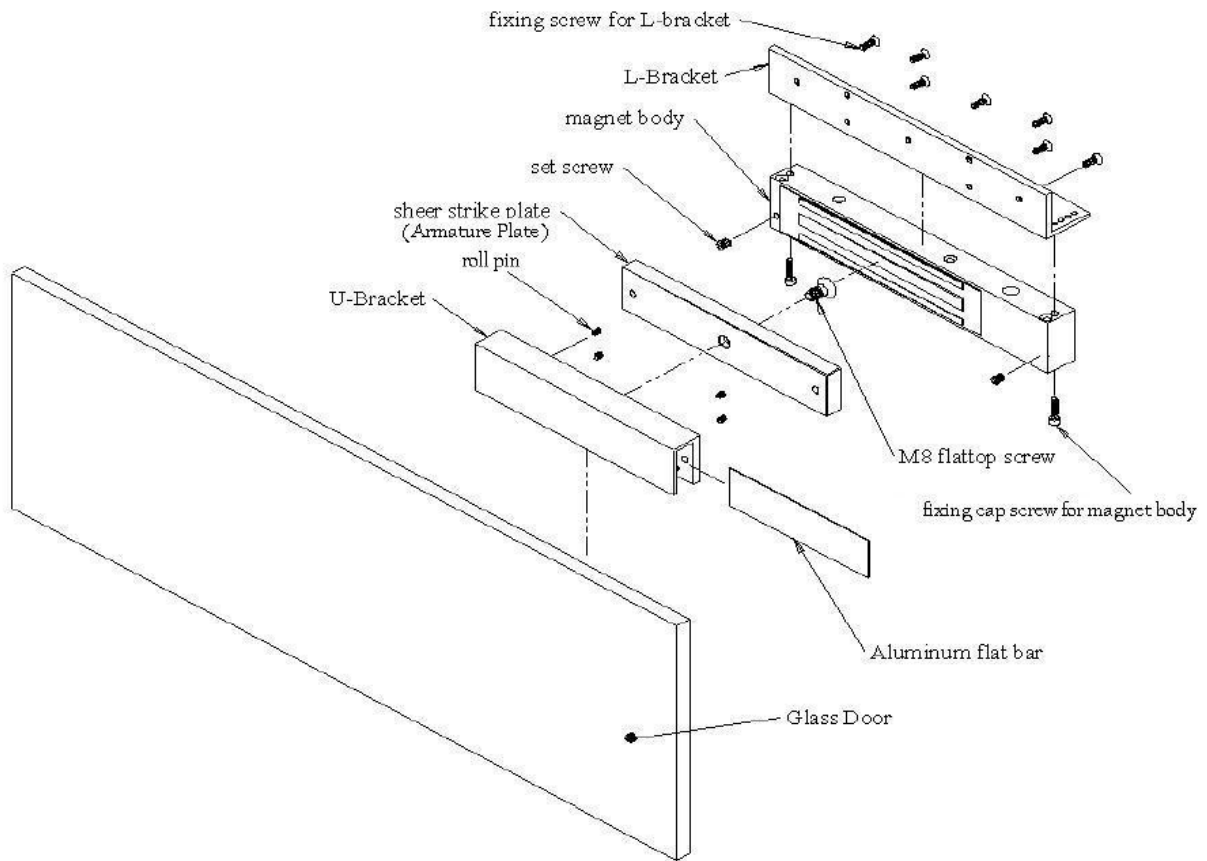

Figure 3: Out-swing door assembly



1. According to the door frame location, set the approximate position of the L-bracket in the door frame. Using the cap screw at 2 interior side affix the magnet body to the L-bracket.
2. Accommodate the sheer strike plate (armature plate) to the U-bracket, lock to the door. Make sure it is at relative position to the magnet body. The U-bracket fixing-screw can adjust forward or backward to make the distance between magnet body and sheer strike plate properly when door closed. Then, lock the U-bracket fixing-screw tightly.
Note: To prevent damaged on the glass door, U-bracket fixing-screw must accommodate with aluminium flat bar.
3. There must have 2 seals and 1 rubber seal between sheer strike plate and U-bracket. Put rubber seal between 2 seals. Lock the M8 flattop screw on the middle of the sheer strike plate to U-bracket. Make sure the sheer strike plate can be slightly shaken when locked. This will have better conjunction to the magnet body, and reach the best efficiency.

Figure 3a
With L bracket & U Bracket (For Glass door)

